



# FUJIAN YAHENG POWER TECHNOLOGY GROUP CO.,LTD



## 6GFM250 12V250AH

6GFM250 is a general purpose battery with 15 years floating design life, meet with IEC,JIS standard. With heavy duty grid thickness plates, special additives, FM series battery have long and reliable standby service life.

### Specification

Cells Per Unit	6
Voltage Per Unit	12V
Capacity	250AH@10hr-rate to 1.75V per cell @ 25°C
Weight	Approx. 72kg (Tolerance±3%)
Max. Discharge Current	2500A(5sec)
Internal Temperature Range	Discharge: -20°C~60°C Charge: 0°C~50°C Storage: -20°C~60°C
Normal Operating Temperature Range	25±5°C
Float Charging Voltage	13.6 to 13.8 VDC/unit Average at 25°C
Recommended Maximum Charging	75.0A Current Limit
Equalization and Cycle service	14.6 to 14.8 VDC /unit Average at 25°C
Self Discharge	YAHENG Vale Regulated Lead Acid(VRLA) Can be stored for more than 6 months at 25°C. Self-discharge ratio less than 3% per month at 25°C. Please charge batteries before using
Terminal	Terminal F18/L22
Container Material	A.B.S. UL94-HB, Flammability resistance of UL94-V2 can be avail upon request

### Dimensions

Unit: mm Dimension: 521(L) × 269(W) × 204 (H) × 209(TH)

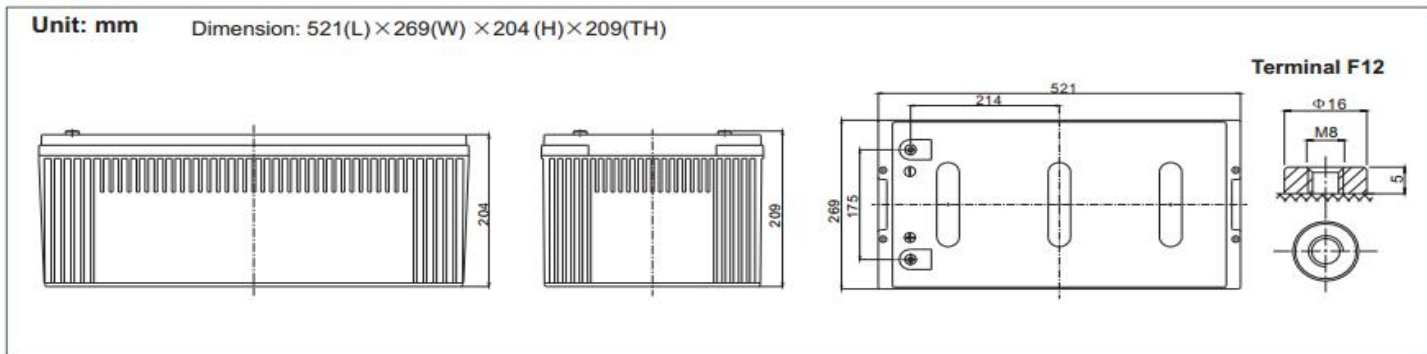

### Constant Current Discharge Characteristics: A(25°C)

F.V/Time	5MIN	10MIN	15MIN	30MIN	1HR	2HR	3HR	4HR	5HR	8HR	10HR	20HR
9.60V	708.65	530.83	448.09	292.93	169.00	101.12	69.896	57.283	46.887	32.297	27.308	15.019
10.0V	688.17	505.08	438.90	288.09	168.22	100.36	69.628	57.018	46.612	32.034	27.045	14.746
10.2V	667.77	487.26	432.01	285.54	166.66	99.60	69.092	56.753	46.336	31.771	26.783	14.473
10.5V	599.63	449.62	411.33	278.41	165.10	98.84	68.825	56.222	45.784	31.509	26.520	14.200
10.8V	541.22	410.01	379.16	266.18	161.20	97.070	66.950	54.896	44.957	30.984	26.257	13.927
11.1V	462.12	366.43	340.09	249.37	153.14	92.761	64.004	52.244	43.026	29.671	25.470	13.108

### Constant Power Discharge Characteristics: W(25°C)

F.V/Time	5MIN	10MIN	15MIN	30MIN	1HR	2HR	3HR	4HR	5HR	8HR	10HR	20HR
9.60V	7329.7	5653.4	4929.0	3339.4	1952.9	1191.9	831.76	682.82	559.37	385.62	326.33	180.08
10.0V	7185.3	5480.2	4849.9	3298.6	1948.2	1185.6	832.05	681.94	557.94	383.77	324.27	176.95
10.2V	7103.2	5335.5	4795.3	3275.2	1933.2	1178.5	828.42	680.47	556.03	381.26	321.39	173.68
10.5V	6466.6	4968.3	4574.0	3198.9	1915.8	1169.9	825.21	674.11	549.41	378.11	318.24	170.40
10.8V	5889.8	4579.8	4227.6	3066.4	1880.4	1155.0	802.73	658.76	539.48	371.81	315.09	167.12
11.1V	5773.3	4140.7	3805.6	2880.3	1799.9	1112.1	768.05	626.93	516.31	356.05	305.64	157.29

All mentioned values are average values.



# FUJIAN YAHENG POWER TECHNOLOGY GROUP CO.,LTD

## Temperature and Valid Capacity



## Discharge Characteristics at Various Rates @25°C/77



## Charge characteristic curve for standby use



## Storage characteristic



## Discharge Current VS. Discharge Voltage

Final Discharge Voltage V/cell	1.75V	1.75V	1.60V
Discharge Current (A)	$A \leq 0.2C$	$0.2C \leq A \leq 1.0C$	$\geq 1.0C$

Charge the batteries at least once every six months, if they are stored at 25°C

Charging Method:

Constant Voltage	$-0.2C * 2h + 2.4 - 2.45V/cell * 24h$ , Max. Current 0.3CA
Constant Current	$-0.2C * 2h + 0.1CA * 12h$
Fast	$-0.2C * 2h + 0.3CA * 4.0h$

## Maintenance & Cautions

### Float Service

- ✘ Every month, recommend inspection every battery voltage
  - ✘ Every three months, recommend equalization charge for one time.
- Equalization charge method:
- Discharge: 100% rate capacity discharge.
- Charge: Max. Current 0.3CA, constant voltage 2.4-2.45V/Cell charge 24h
- ✘ Effect of temperature on float charge voltage: -3mV/Cell.
  - ✘ Length of service life will be directly affected by the number of discharge cycles, depth of discharge, ambient temperature and charging voltage.

## Contact us:

Fujian Yaheng Power Technology Group Co.,Ltd

Add: Yaheng Industrial Park, Jianyang District, Nanping City, Fujian Province, China

Website: [www.yahengpower.com](http://www.yahengpower.com)

Email: [liwendu@yahengpower.com](mailto:liwendu@yahengpower.com)

Tel: +86-599-5837578 Fax: +86-599-5823986