



FUJIAN YAHENG POWER TECHNOLOGY GROUP CO.,LTD

GEL 6FM55T 12V55AH

6FM55T is a deep cycle purpose GEL battery . with specially designed for frequent cyclic discharge usage. By using strong grid and specific paste plate, the battery offers 50% more cyclic life than the standby series. It is applicable for power tools, solar & wind energy, telecom system, etc..



Specification

Cells Per Unit	6
Voltage Per Unit	12V
Capacity	55AH@20hr-rate to 1.75V per cell @ 25°C
Weight	Approx. 18.0kg (Tolerance±3%)
Max. Discharge Current	550A(5sec)
Internal Temperature Range	Discharge: -20°C~60°C Charge: 0°C~50°C Storage: -20°C~60°C
Normal Operating Temperature Range	25±5°C
Float Charging Voltage	13.6 to 13.8 VDC/unit Average at 25°C
Recommended Maximum Charging	16.5A
Equalization and Cycle service	14.4 to 14.8 VDC /unit Average at 25°C
Self Discharge	YAHENG Vale Regulated Lead Acid(VRLA) Can be stored for more than 6 months at 25°C. Self-discharge ratio less than 3% per month at25°C. Please charge batteries before using.
Terminal	Terminal F11
Container Material	A.B.S. UL94-HB, Flammability resistance of UL94-V2 can be avail upon request

Dimensions

Unit: mm Dimension: 277(L)×106(W)×222(H)

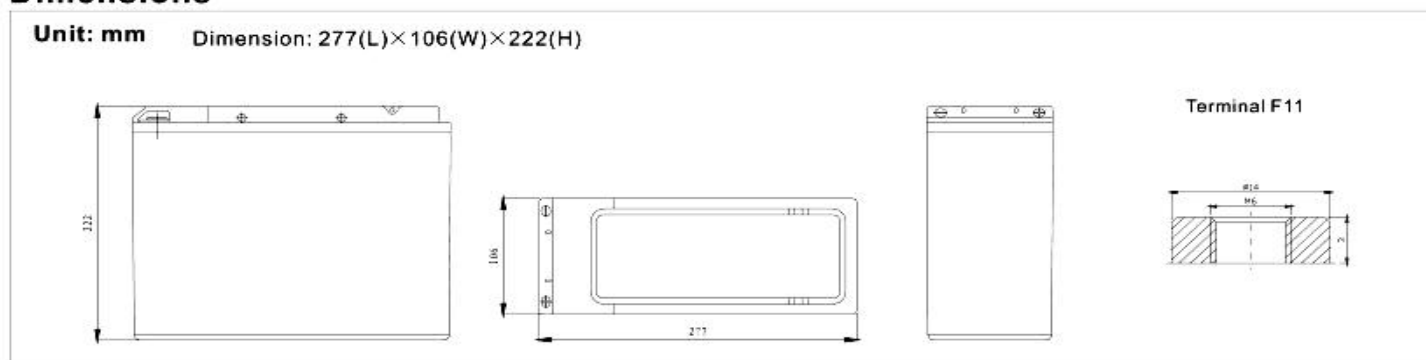

Constant Current Discharge Characteristics: A(25°C)

F.V/Time	5MIN	10MIN	15MIN	30MIN	1HR	2HR	3HR	4HR	5HR	8HR	10HR	20HR
9.60V	184.3	135.7	105.8	64.46	35.75	21.38	14.76	12.23	10.30	7.033	5.833	3.113
10.0V	179.0	129.1	103.6	63.34	35.59	21.22	14.71	12.17	10.24	6.976	5.777	3.056
10.2V	173.7	124.5	101.97	62.17	35.26	21.06	14.59	12.12	10.17	6.919	5.721	2.999
10.5V	155.9	114.9	97.09	61.70	34.93	20.90	14.54	12.00	10.05	6.861	5.665	2.943
10.8V	140.7	104.8	89.50	60.65	34.10	20.52	14.14	11.72	9.872	6.747	5.609	2.886
11.1V	120.2	93.7	80.28	56.78	32.40	19.61	13.52	11.15	9.448	6.461	5.441	2.716

Constant Power Discharge Characteristics: W(25°C)

F.V/Time	5MIN	10MIN	15MIN	30MIN	1HR	2HR	3HR	4HR	5HR	8HR	10HR	20HR
9.60V	1944	1445	1153	723.3	413.1	252.0	175.7	145.8	122.8	83.97	69.71	37.32
10.0V	1906	1401	1135	714.4	412.1	250.7	175.7	145.6	122.5	83.57	69.27	36.67
10.2V	1884	1364	1122	709.4	408.9	249.1	175.0	145.3	122.1	83.02	68.65	35.99
10.5V	1715	1270	1070	704.5	405.3	247.3	174.3	143.9	120.6	82.34	67.98	35.31
10.8V	1562	1171	989.0	693.2	397.8	244.2	169.6	140.6	118.5	80.96	67.31	34.63
11.1V	1372	1058	890.3	652.9	380.8	235.1	162.2	133.8	113.4	77.53	65.29	32.60

All mentioned values are average values.



FUJIAN YAHENG POWER TECHNOLOGY GROUP CO.,LTD

Temperature and Valid Capacity

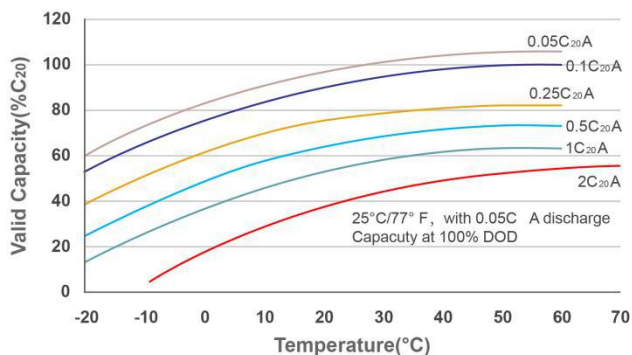

Discharge Characteristics at Various Rates @25°C/77

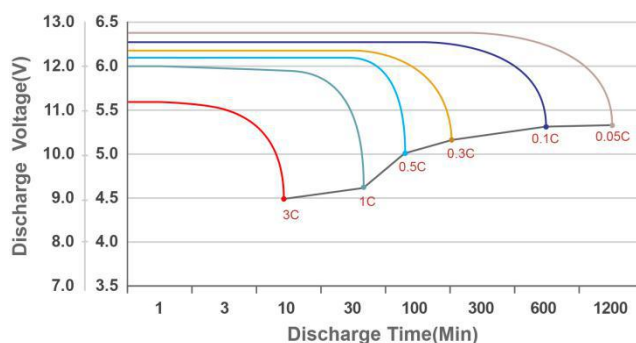

Charge characteristic curve for standby use

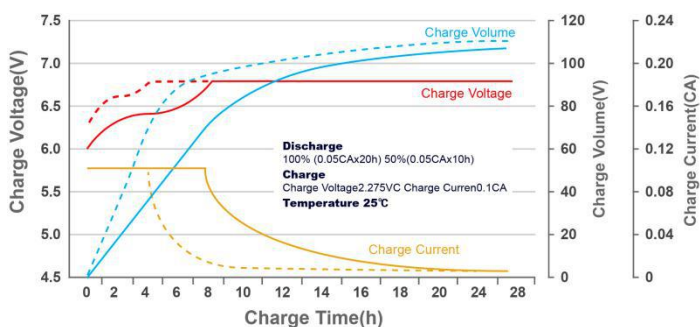

Life characteristics of cyclic use

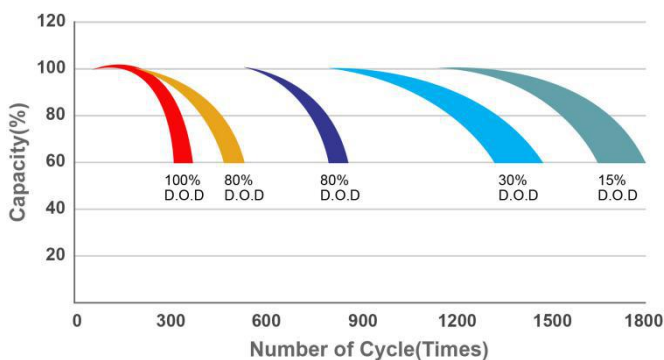

Discharge Current VS. Discharge Voltage

Final Discharge Voltage V/cell	1.75V	1.75V	1.60V
Discharge Current (A)	A ≤ 0.2C	0.2C ≤ A ≤ 1.0C	≥ 1.0C

Charge the batteries at least once every six months, if they are stored at 25°C

Charging Method:

Constant Voltage	-0.2C*2h+2.4-2.45V/cell*24h, Max.Current 0.3CA
Constant Current	-0.2C*2h+0.1CA*12h
Fast	-0.2C*2h+0.3CA*4.0h

Maintenance & Cautions

Float Service

- ✘ Every month, recommend inspection every battery voltage
 - ✘ Every three months, recommend equalization charge for one time.
- Equalization charge method:
- Discharge: 100% rate capacity discharge.
- Charge: Max. Current 0.3CA, constant voltage 2.4-2.45V/Cell charge 24h
- ✘ Effect of temperature on float charge voltage: -3mV/Cell.
 - ✘ Length of service life will be directly affected by the number of discharge cycles, depth of discharge, ambient temperature and charging voltage.

Contact us:

Fujian Yaheng Power Technology Group Co.,Ltd

Add: Yaheng Industrial Park, Jianyang District, Nanping City, Fujian Province, China

Website: www.yahengpower.com

Email: liwendu@yahengpower.com

Tel: +86-599-5837578 Fax: +86-599-5823986