



FUJIAN YAHENG POWER TECHNOLOGY GROUP CO.,LTD

GEL GFM600D 2V600AH

GFM600D is a deep cycle purpose GEL battery . with specially designed for frequent cyclic discharge usage. By using strong grid and specific paste plate, the battery offers 50% more cyclic life than the standby series. It is applicable for power tools, solar & wind energy, telecom system, etc..



Specification

Cells Per Unit	1
Voltage Per Unit	2V
Capacity	600AH@10hr-rate to 1.75V per cell @ 25°C
Weight	Approx. 41.0kg (Tolerance±3%)
Max. Discharge Current	3000A(5sec)
Internal Temperature Range	Discharge: -20°C~60°C Charge: 0°C~50°C Storage: -20°C~60°C
Normal Operating Temperature Range	25±5°C
Float Charging Voltage	2.27 to 2.3 VDC/unit Average at 25°C
Recommended Maximum Charging	180.0A
Equalization and Cycle service	2.4 to 2.47 VDC /unit Average at 25°C
Self Discharge	YAHENG Vale Regulated Lead Acid(VRLA) Can be stored for more than 6 months at 25°C. Self-discharge ratio less than 3% per month at 25°C. Please charge batteries before using.
Terminal	Terminal F10
Container Material	A.B.S. UL94-HB, Flammability resistance of UL94-V2 can be avail upon request

Dimensions

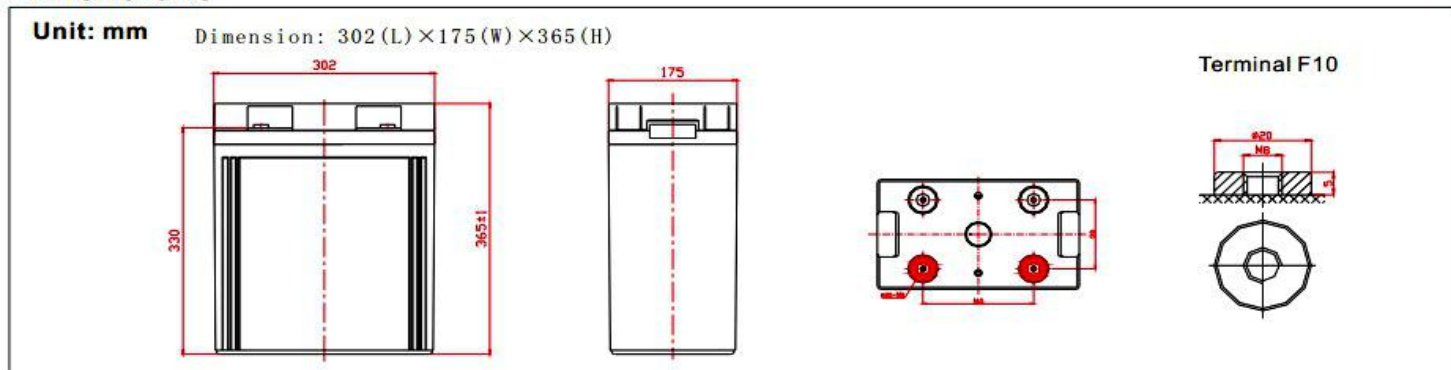

Constant Current Discharge Characteristics: A(25°C)

F.V/Time	15MIN	30MIN	1HR	2HR	3HR	4HR	5HR	6HR	8HR	10HR
1.60V	814.6	600.8	386.6	229.8	171.2	136.5	114.9	96.51	77.91	65.12
1.65V	774.6	576.8	369.9	221.4	164.0	131.7	110.1	94.19	74.42	63.99
1.70V	722.3	543.8	362.7	217.9	160.4	130.5	108.9	91.86	73.26	62.83
1.75V	641.3	489.4	334.0	205.9	152.0	123.3	104.1	87.21	70.93	61.67
1.80V	552.0	445.7	314.8	196.3	146.0	122.1	100.5	86.05	69.77	60.50
1.85V	466.8	401.3	290.9	185.5	138.9	112.5	95.76	81.40	66.28	56.41

Constant Power Discharge Characteristics: W(25°C)

F.V/Time	15MIN	30MIN	1HR	2HR	3HR	4HR	5HR	6HR	8HR	10HR
1.60V	1426	1095	707.9	425.7	319.0	256.4	217.2	186.2	148.3	125.7
1.65V	1389	1089	705.5	419.6	312.7	252.6	214.7	183.8	147.0	124.5
1.70V	1312	1031	692.6	413.5	308.0	251.6	212.8	179.6	144.7	122.6
1.75V	1169	928.8	638.0	391.4	296.9	239.0	203.9	170.7	140.2	120.6
1.80V	1011	847.4	601.6	373.8	284.6	237.9	197.3	168.7	137.9	116.3
1.85V	862.6	764.0	556.1	353.8	271.2	220.4	188.2	159.8	131.1	112.0

All mentioned values are average values.



FUJIAN YAHENG POWER TECHNOLOGY GROUP CO.,LTD

Temperature and Valid Capacity

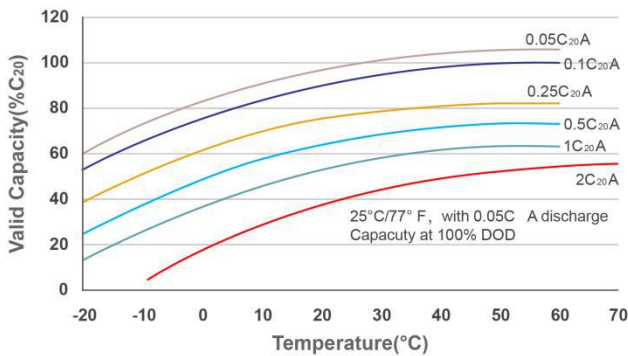

Discharge Characteristics at Various Rates @25°C/77



Charge characteristic curve for standby use



Life characteristics of cyclic use

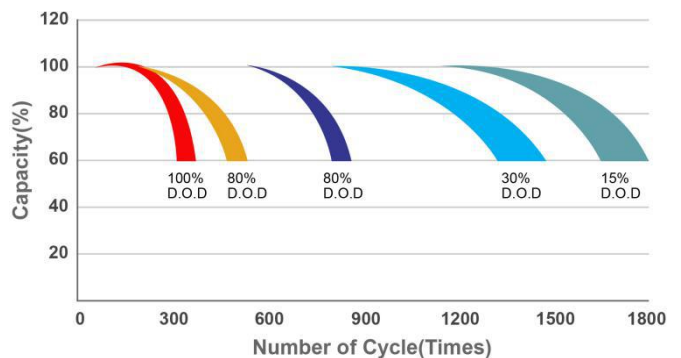

Discharge Current VS. Discharge Voltage

Final Discharge Voltage V/cell	1.75V	1.75V	1.60V
Discharge Current (A)	$A \leq 0.2C$	$0.2C \leq A \leq 1.0C$	$\geq 1.0C$

Charge the batteries at least once every six months, if they are stored at 25°C

Charging Method:

Constant Voltage	$-0.2C*2h + 2.4-2.45V/cell*24h$, Max.Current 0.3CA
Constant Current	$-0.2C*2h + 0.1CA*12h$
Fast	$-0.2C*2h + 0.3CA*4.0h$

Maintenance & Cautions

Float Service

- ✘ Every month, recommend inspection every battery voltage
 - ✘ Every three months, recommend equalization charge for one time.
- Equalization charge method:
- Discharge: 100% rate capacity discharge.
- Charge: Max. Current 0.3CA, constant voltage 2.4-2.45V/Cell charge 24h
- ✘ Effect of temperature on float charge voltage: -3mV/Cell.
 - ✘ Length of service life will be directly affected by the number of discharge cycles, depth of discharge, ambient temperature and charging voltage.

Contact us:

Fujian Yaheng Power Technology Group Co.,Ltd

Add: Yaheng Industrial Park, Jianyang District, Nanping City, Fujian Province, China

Website: www.yahengpower.com

Email: liwendu@yahengpower.com

Tel: +86-599-5837578 Fax: +86-599-5823986